

THE EMPIRE STRIKES BACK

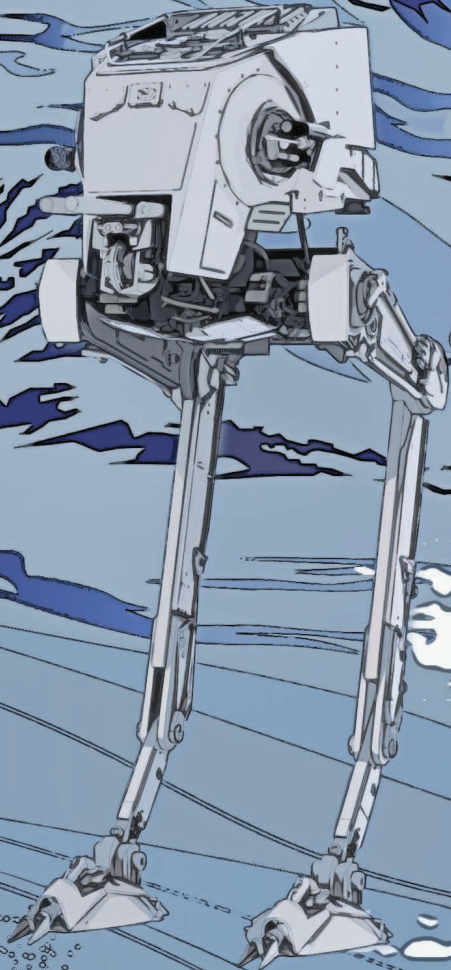

AT-ST BUILDERS GUIDE



TABLE OF CONTENTS

MODULE 1 HEAD	PAGES 4-7
MODULE 2 BODY.....	PAGES 8-11
MODULE 3 LEGS.....	PAGES 12-17
MODULE 4 HOSES.....	PAGES 18
MODULE 5 ASSEMBLY....	PAGES 19-20
MODULE 6 BASE.....	PAGES 21

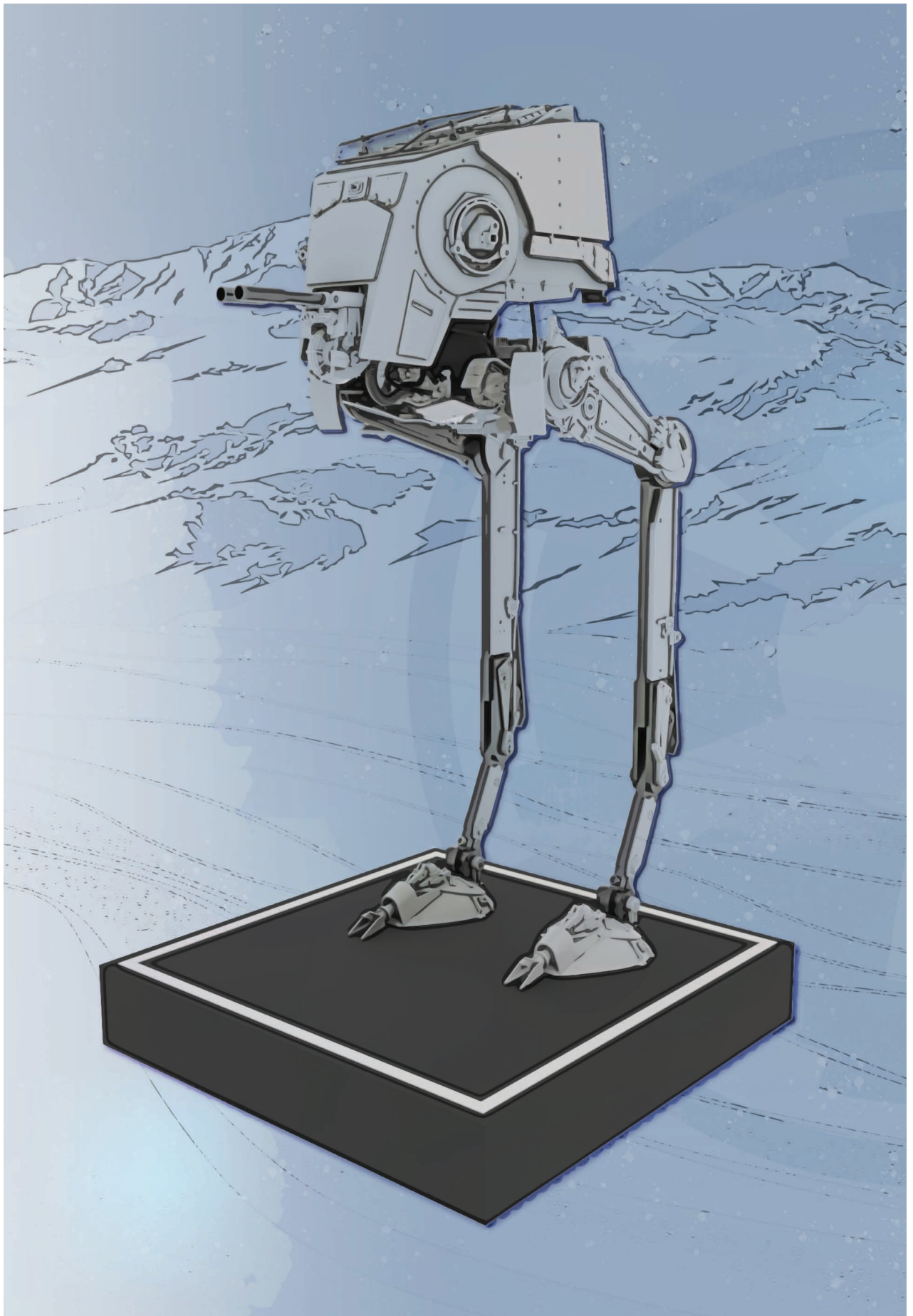

TOOLS



SUPER GLUE OR CA GLUE WILL BE USED FOR ALL PLASTIC TO PLASTIC GLUING AS WELL AS SILICON GLUING



FOR METAL TO METAL OR FOR PLASTIC TO METAL GLUING, WE HAVE FOUND THAT SPECIFICALLY GORILLA "CLEAR GRIP" WORKS THE BEST



YOU WILL NEED A VARIETY OF ALLEN KEYS (1.5MM, 3/32, 4MM)



YOU WILL NEED A STANDARD FLAT HEAD SCREWDRIVER

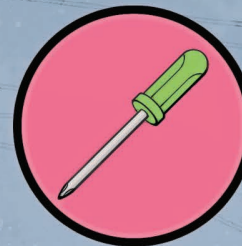

YOU WILL NEED A STANDARD PHILIPS HEAD SCREWDRIVER

Module 1: Head

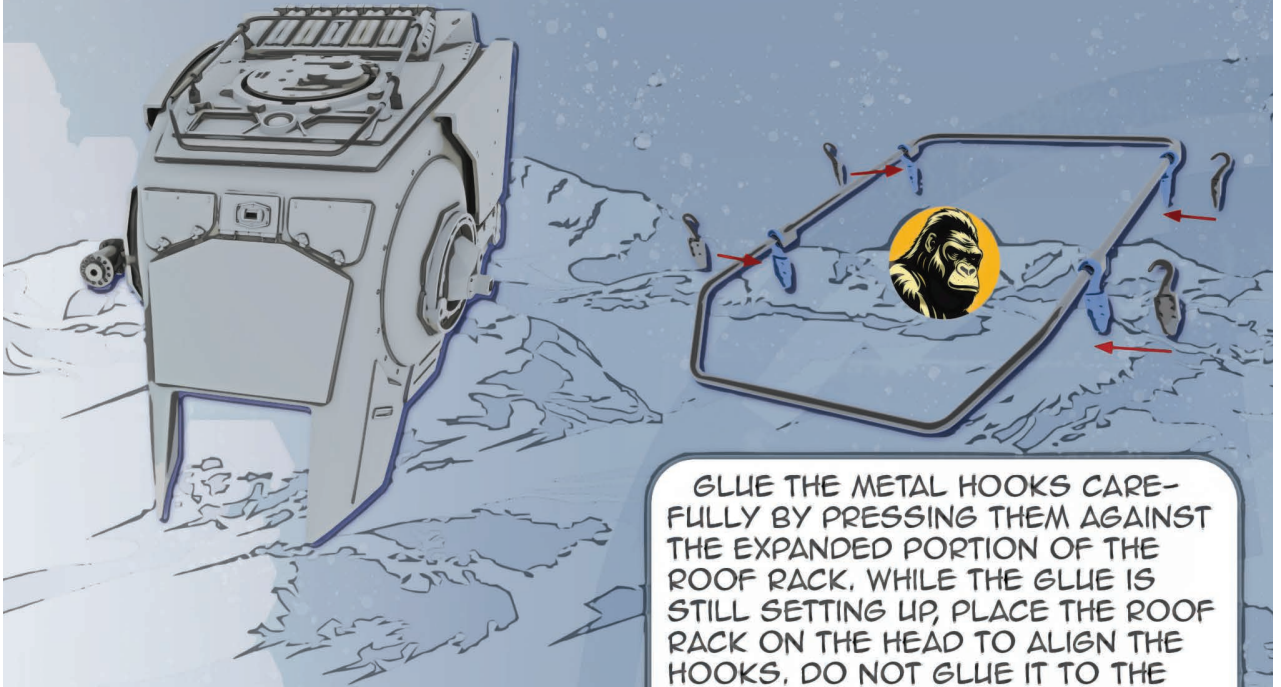

GLUE THE METAL HOOKS CAREFULLY BY PRESSING THEM AGAINST THE EXPANDED PORTION OF THE ROOF RACK. WHILE THE GLUE IS STILL SETTING UP, PLACE THE ROOF RACK ON THE HEAD TO ALIGN THE HOOKS, DO NOT GLUE IT TO THE BODY AT THIS POINT, JUST LET THE GLUE DRY AND THEN REMOVE

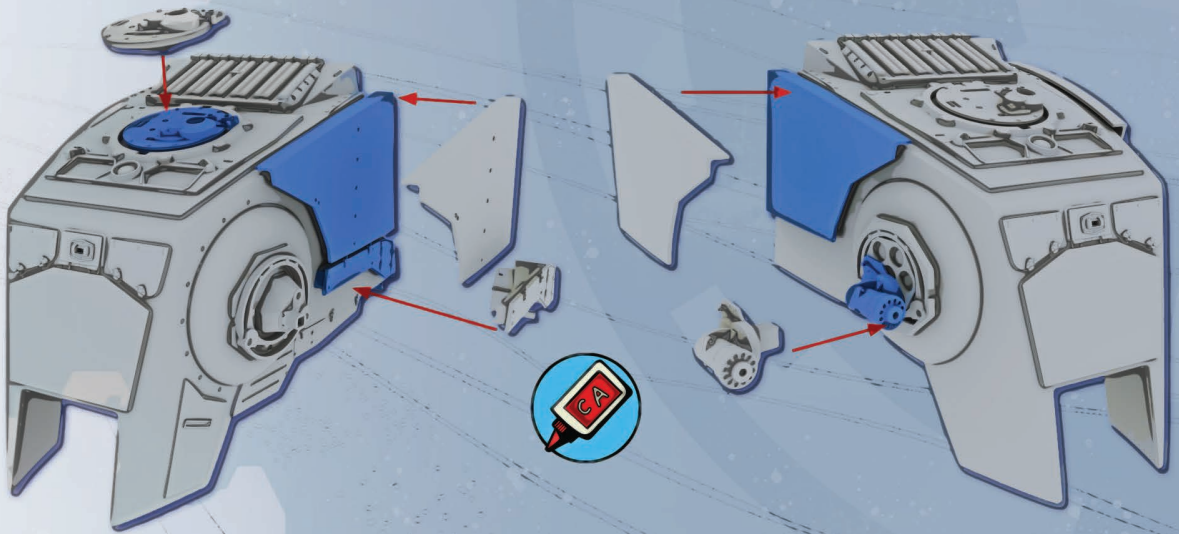

Legend



SUPER GLUE



CLEAR



NO GLUE



FLAT HEAD



PHILLIPS HEAD



ALLEN KEY

Module 1: Head

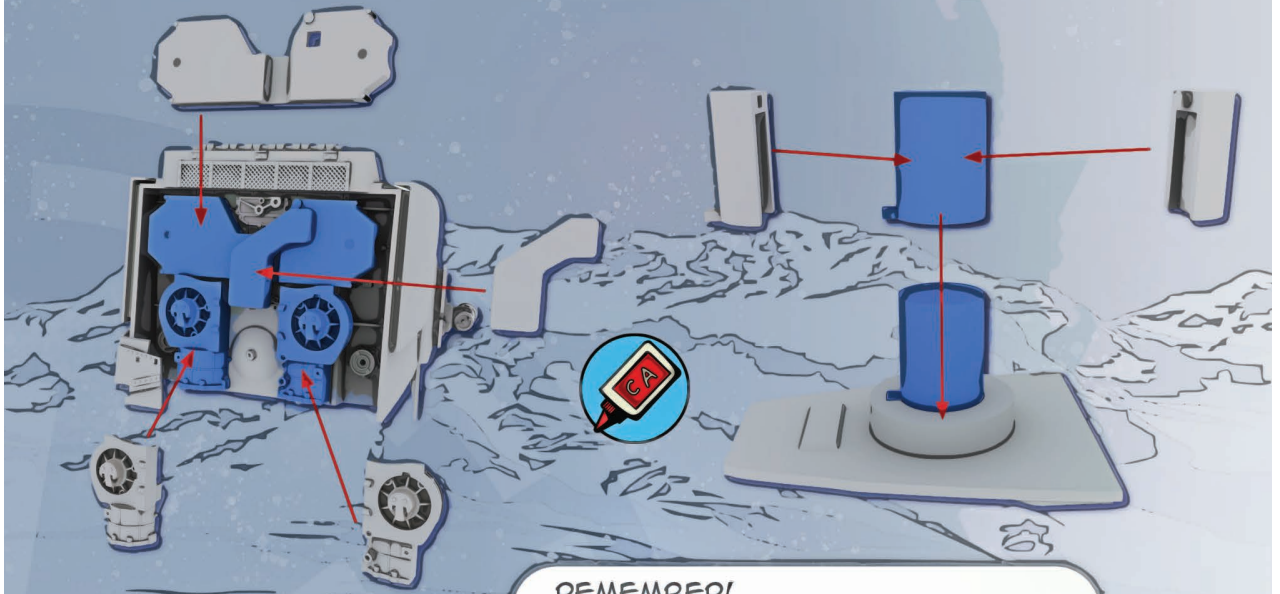

REMEMBER!
USE GORILLA CLEAR GLUE TO
ATTACH THE METAL HOOKS TO THE
HEAD. CLEAR GLUE HAS A STRONG,
FLEXIBLE HOLD AND SHOULD AL-
LOW FOR SOME SMALL ADJUST-
MENT. IT CAN BE REMOVED BY
SCRAPING WITH A KNIFE

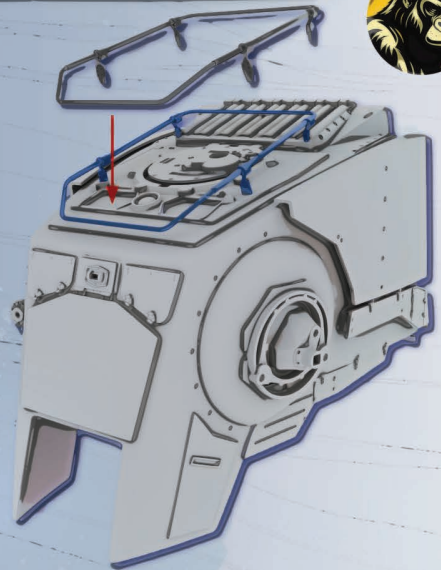
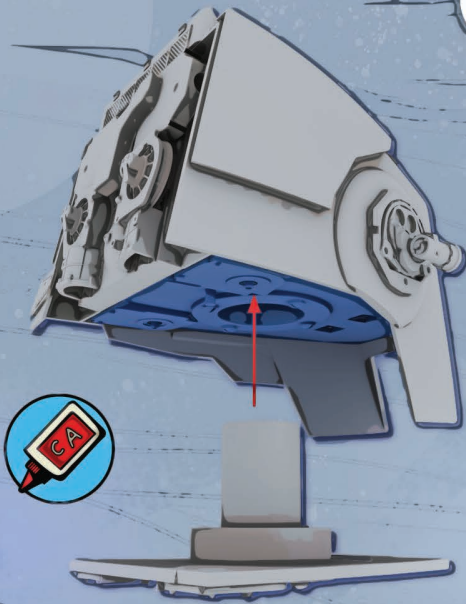

Legend



SUPER GLUE



CLEAR



NO GLUE



FLAT HEAD



PHILLIPS HEAD



ALLEN KEY

Module 1: Head

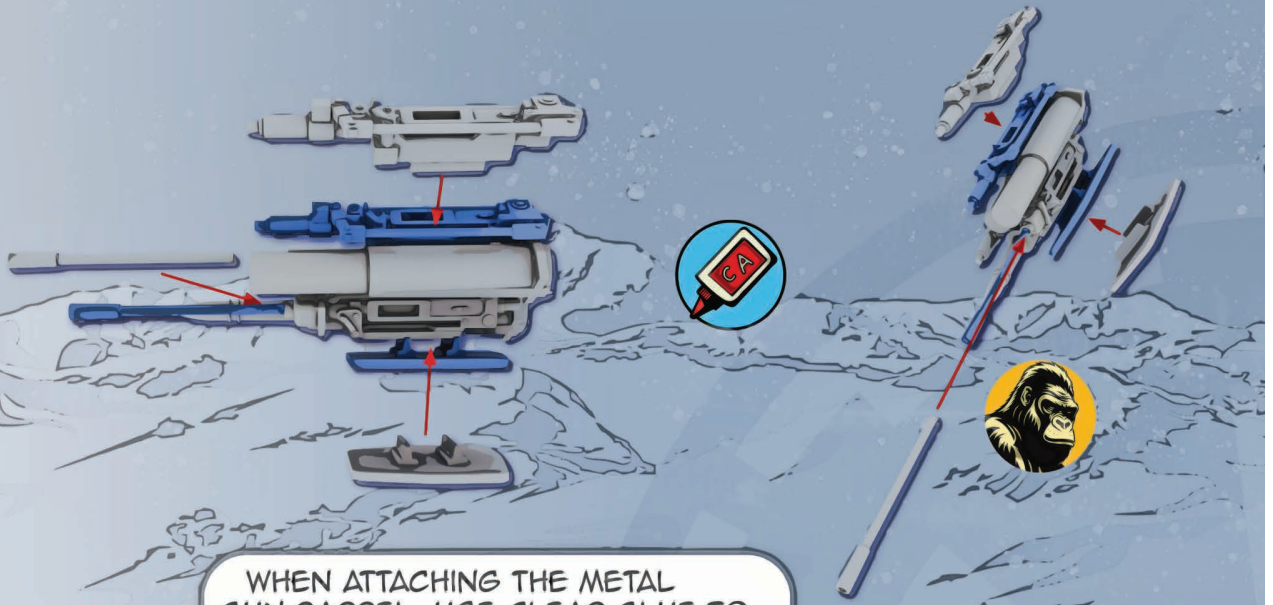

WHEN ATTACHING THE METAL GUN BARREL, USE CLEAR GLUE TO CREATE A STRONG, FLEXIBLE BOND THAT WILL NOT BREAK OFF IF ACCIDENTLY TAMPERED WITH, YOU CAN SCRAPE OFF THE GLUE AND REAPPLY IN CASE OF ACCIDENTS

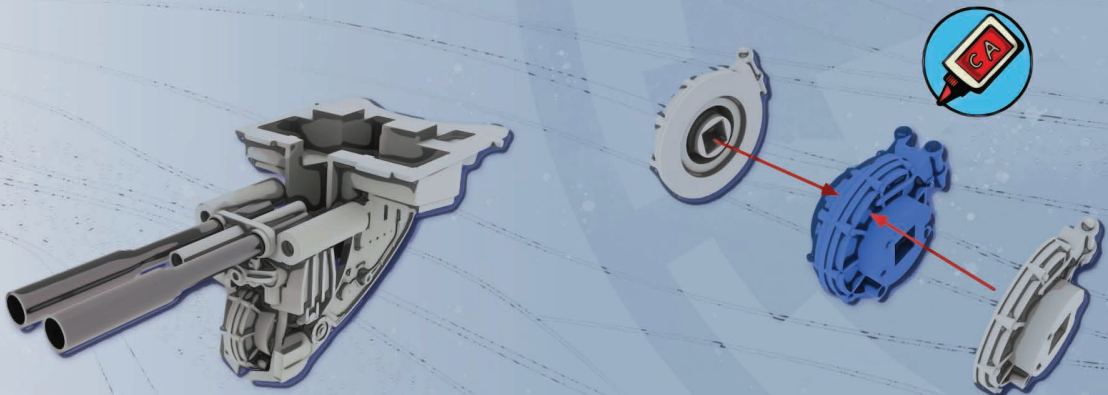

Legend



SUPER GLUE



CLEAR



NO GLUE



FLAT HEAD



PHILLIPS HEAD



ALLEN KEY

Module 1: Head

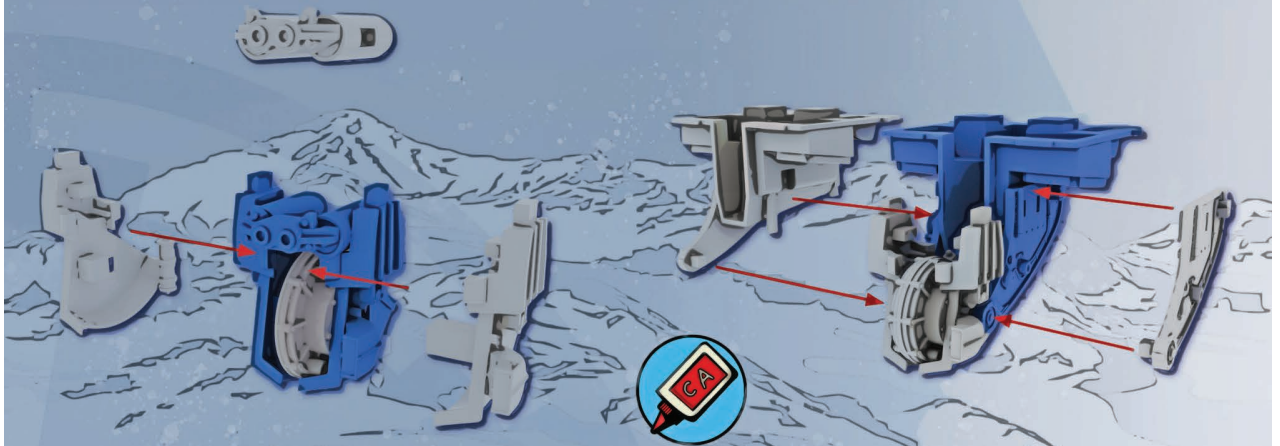

GLUE THE GUN BARRELS FROM THE REAR, APPLY THE CLEAR GLUE TO THE PLASTIC PIECE, NOT THE METAL BARRELS, THEN SLIDE THE BARRELS INTO THE PLASTIC PIECE.

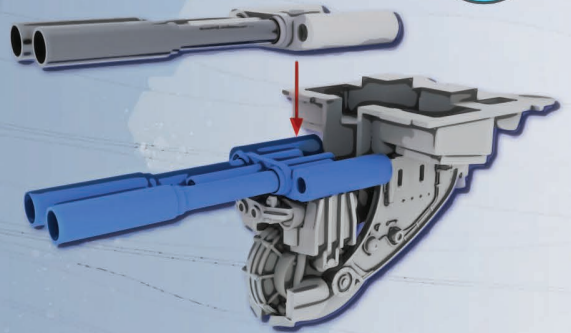
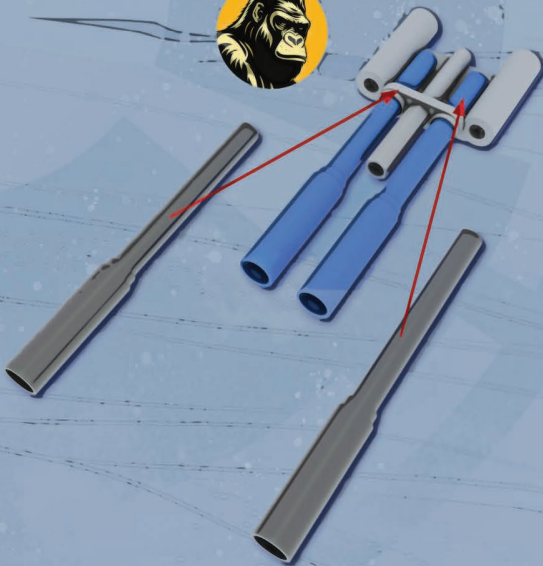

Legend



SUPER GLUE



CLEAR



NO GLUE



FLAT HEAD



PHILLIPS HEAD



ALLEN KEY

Module 2: Body

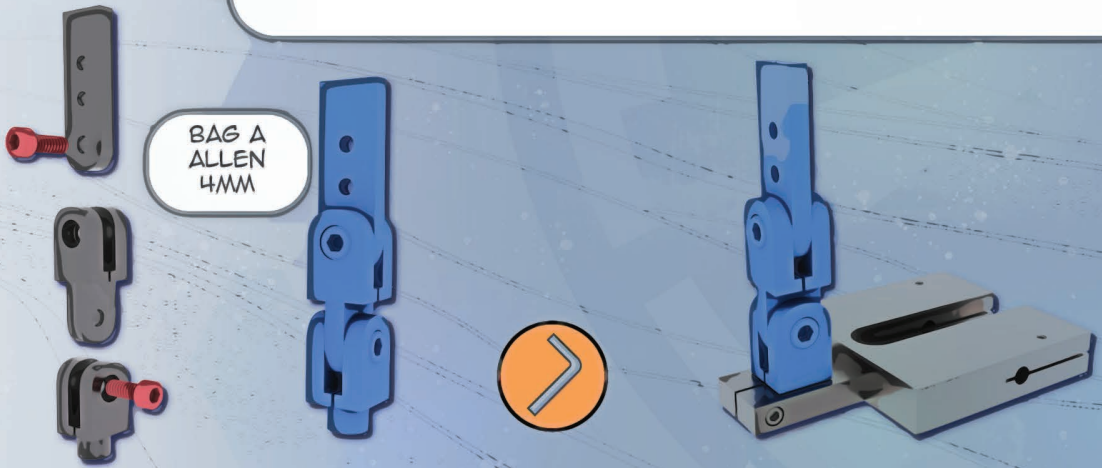
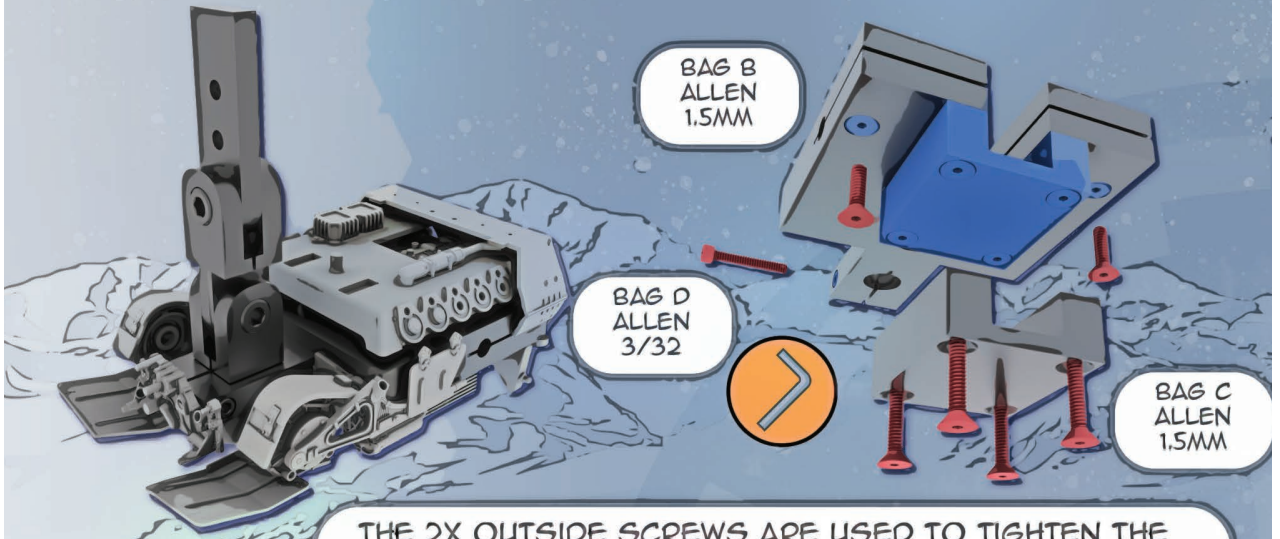

Legend



SUPER GLUE



CLEAR



NO GLUE



FLAT HEAD



PHILLIPS HEAD



ALLEN KEY

Module 2: Body

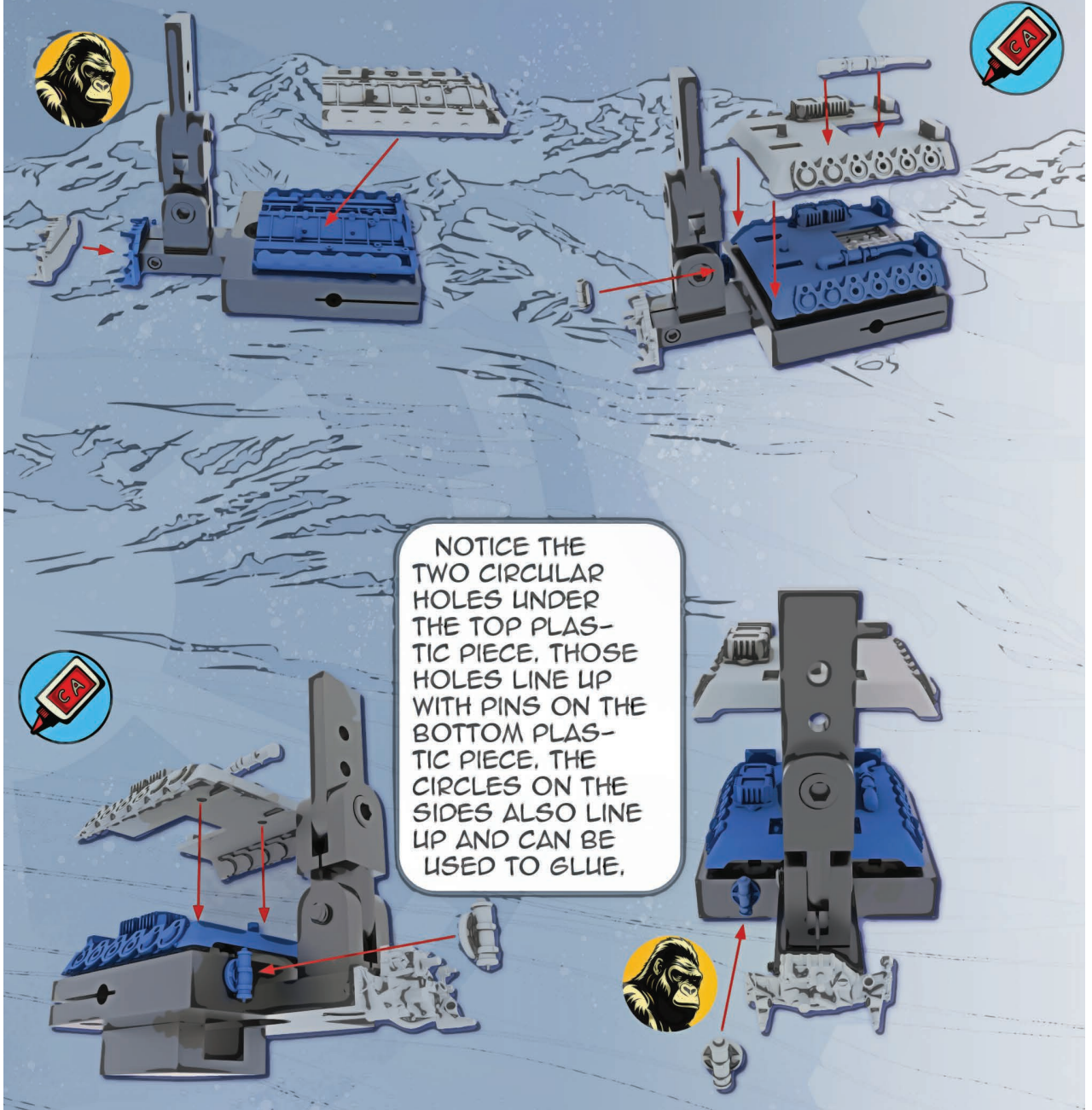

NOTICE THE TWO CIRCULAR HOLES UNDER THE TOP PLASTIC PIECE, THOSE HOLES LINE UP WITH PINS ON THE BOTTOM PLASTIC PIECE, THE CIRCLES ON THE SIDES ALSO LINE UP AND CAN BE USED TO GLUE.

Legend



SUPER GLUE



CLEAR



NO GLUE



FLAT HEAD



PHILLIPS HEAD



ALLEN KEY

Module 2: Body

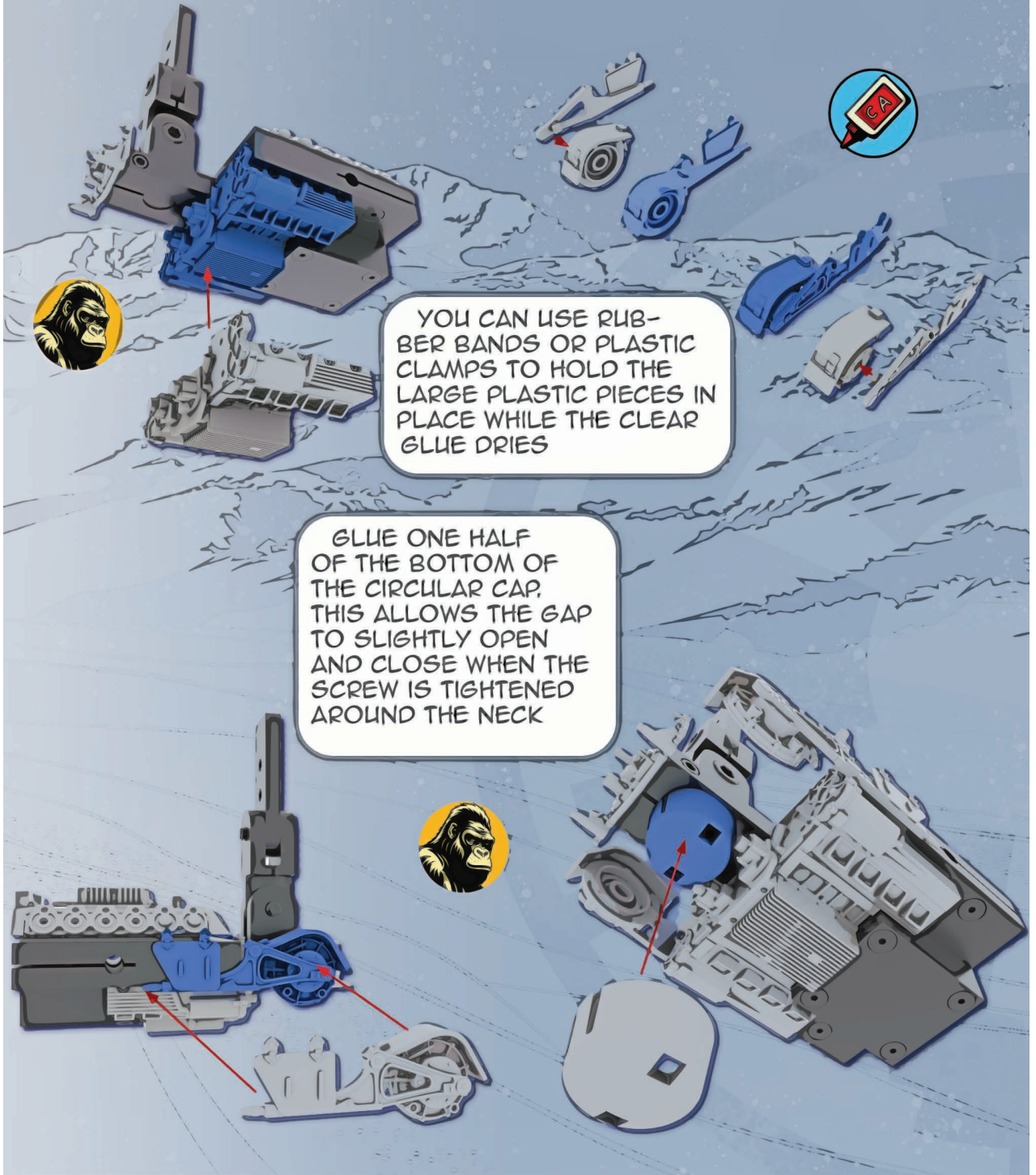

YOU CAN USE RUBBER BANDS OR PLASTIC CLAMPS TO HOLD THE LARGE PLASTIC PIECES IN PLACE WHILE THE CLEAR GLUE DRIES

GLUE ONE HALF OF THE BOTTOM OF THE CIRCULAR CAP. THIS ALLOWS THE GAP TO SLIGHTLY OPEN AND CLOSE WHEN THE SCREW IS TIGHTENED AROUND THE NECK

Legend

					
SUPER GLUE	CLEAR	NO GLUE	FLAT HEAD	PHILLIPS HEAD	ALLEN KEY

Module 2: Body

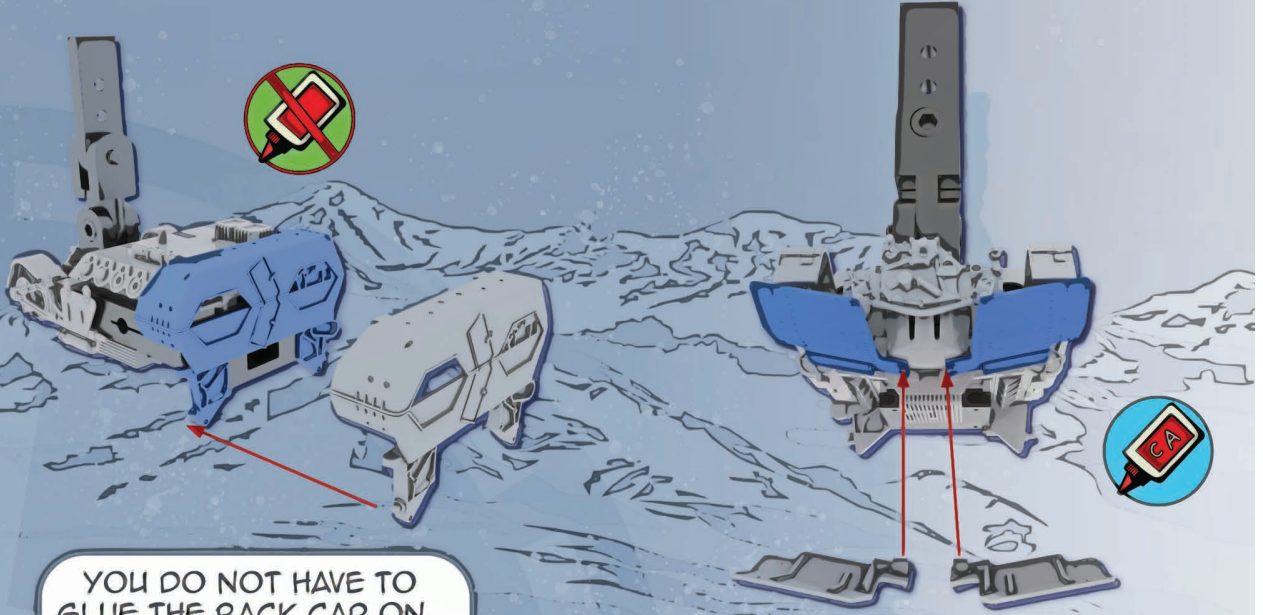

YOU DO NOT HAVE TO GLUE THE BACK CAP ON, THIS PIECE WILL TIGHTLY SLIDE ONTO THE BODY

WHEN THESE BOTTOM SHIELDS ARE INSTALLED THE BODY BECOMES MORE FRAGILE, I SAVE THESE FOR WHEN I FINISH PAINTING THEM BUT YOU CAN CHOOSE WHEN TO INSTALL THEM

Legend



SUPER GLUE



CLEAR



NO GLUE



FLAT HEAD



PHILLIPS HEAD



ALLEN KEY

Module 3: legs

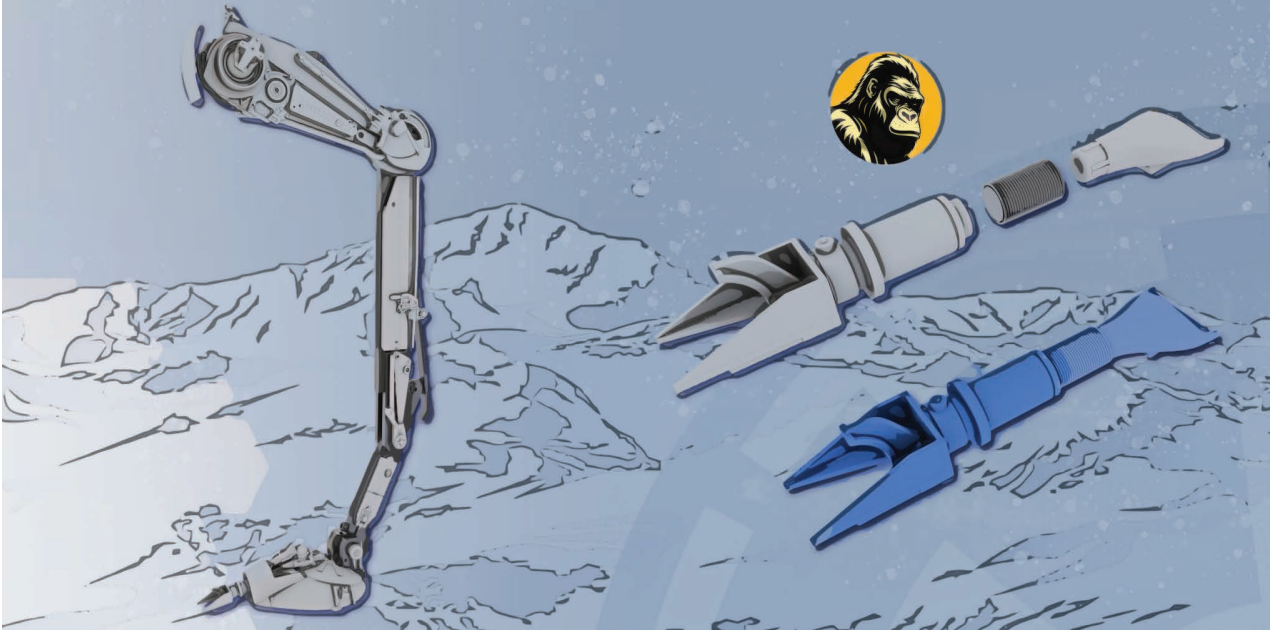

READ THIS!!!!
DO THESE STEPS FOR BOTH LEGS BUT READ THROUGH THE MANUAL FIRST BECAUSE THE RIGHT LEG HAS SOME UNIQUE STEPS AT THE END OF THIS SECTION. PLEASE COMPLETE ONE LEG AT A TIME TO INSURE YOU PUT THE PIECES IN THE RIGHT PLACE

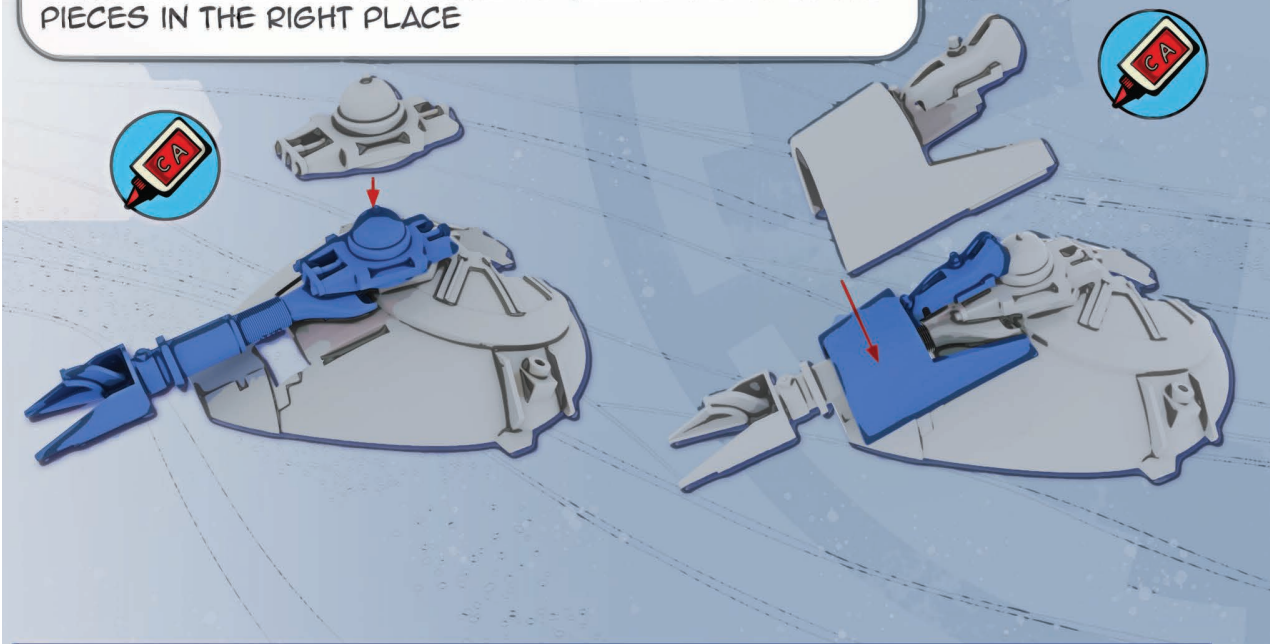

Legend



SUPER GLUE



CLEAR



NO GLUE



FLAT HEAD



PHILLIPS HEAD



ALLEN KEY

Module 3: legs

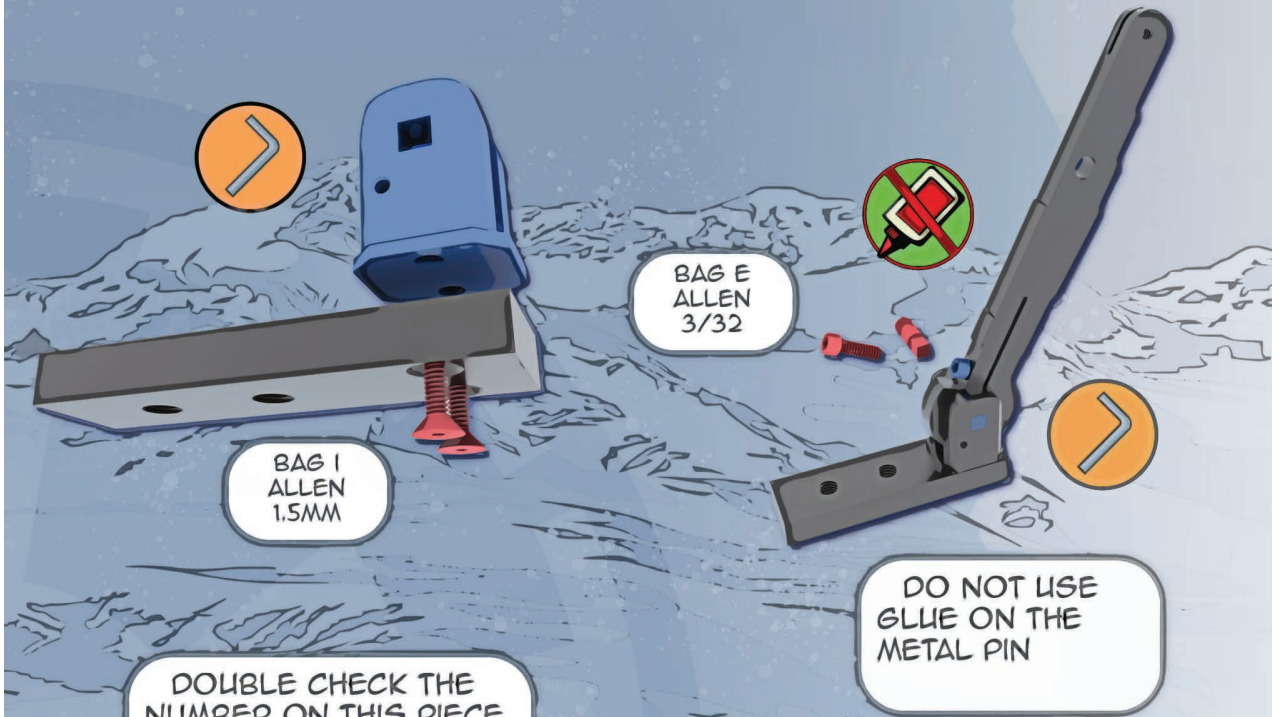

DOUBLE CHECK THE NUMBER ON THIS PIECE TO ENSURE YOU USE THE RIGHT ONE!

DO NOT USE GLUE ON THE METAL PIN

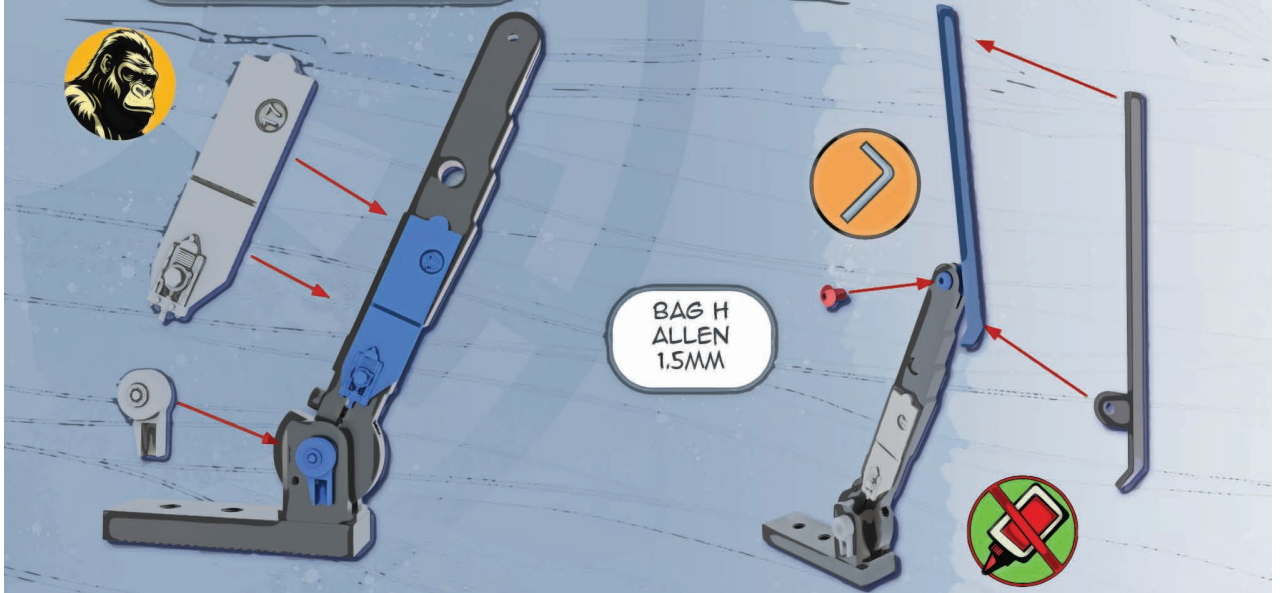

BAG H ALLEN 1.5MM

Legend



SUPER GLUE



CLEAR



NO GLUE



FLAT HEAD



PHILLIPS HEAD



ALLEN KEY

Module 3: legs

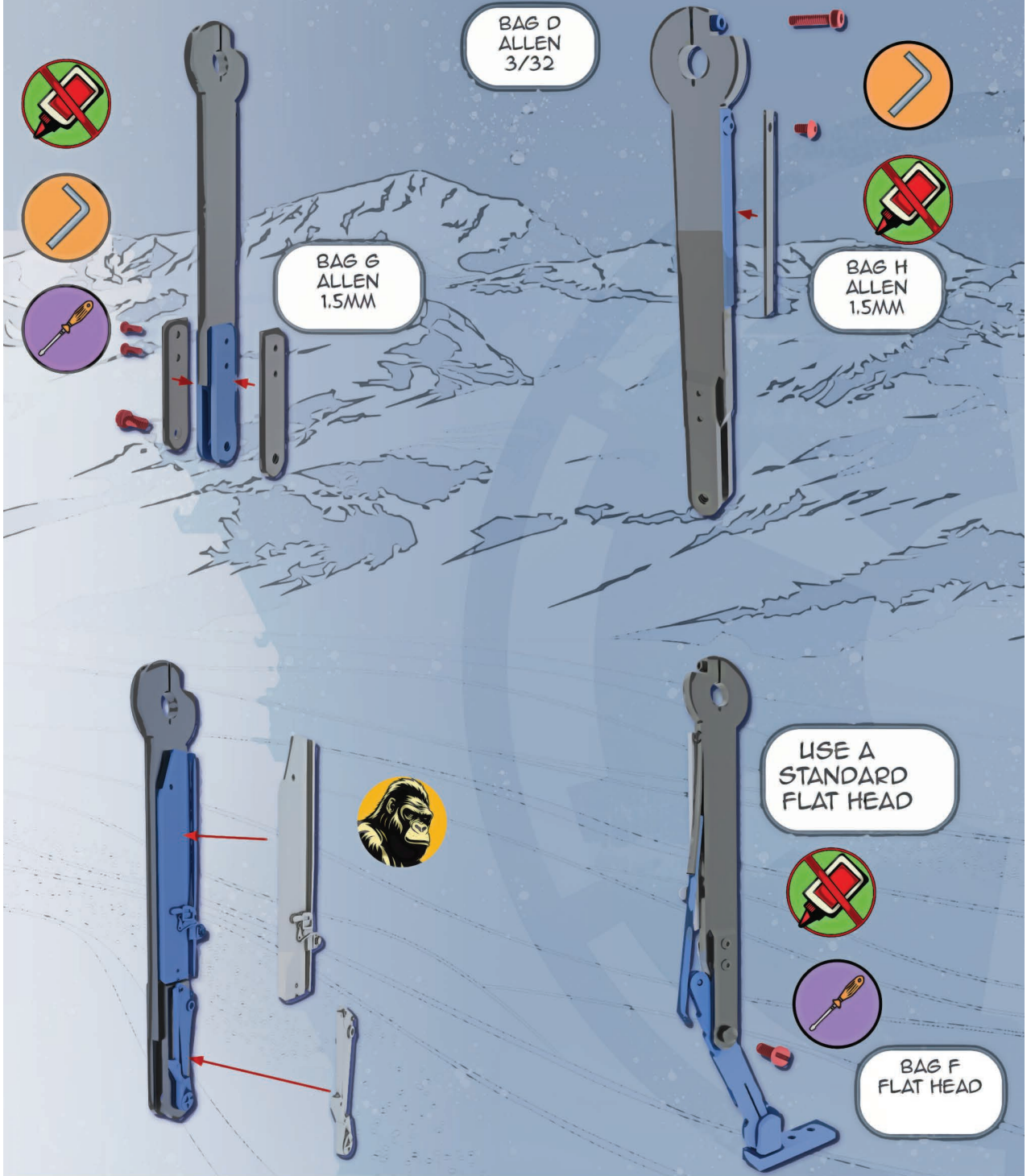

Legend



SUPER GLUE



CLEAR



NO GLUE



FLAT HEAD



PHILLIPS HEAD



ALLEN KEY

Module 3: legs

BAG D
ALLEN
3/32

BAG D
ALLEN
3/32



THE SNAP RINGS ARE DESIGNED TO BE MANUALLY OPENED AND MANUALLY CLOSED. THEY WILL NOT SNAP BACK IN PLACE ON THEIR OWN. BE CAREFUL

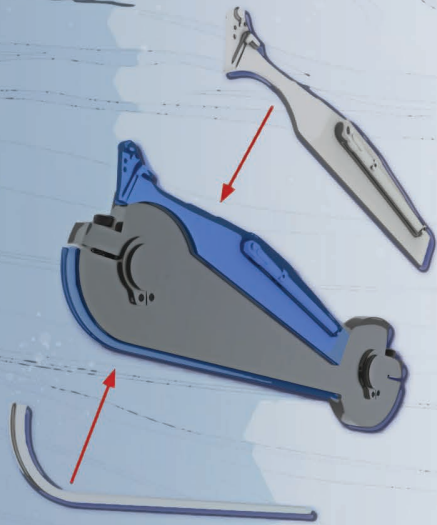
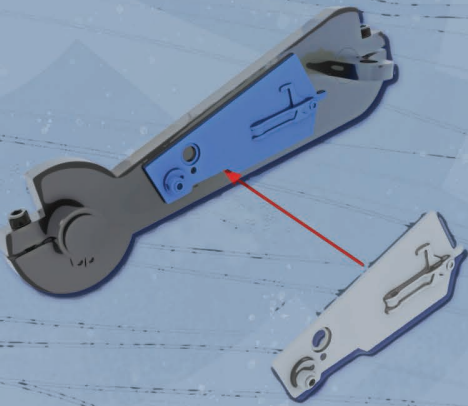

Legend



SUPER GLUE



CLEAR



NO GLUE



FLAT HEAD



PHILLIPS HEAD



ALLEN KEY

Module 3: legs



BAG D
ALLEN
2.5MM

GLUE THIS
PIECE TO THE
PLASTIC PART
ON THE LEFT
ONLY



THIS PART IS VERY
FRAGILE AND CAN
ACCIDENTLY COME
OFF IN THE CASE
OF ANY ACCIDENT,
I CHOSE TO USE A
SMALL AMOUNT OF
CA GLUE SO IT CAN
POP OFF EASILY
WITHOUT BREAKING

BAG A
ALLEN
4MM

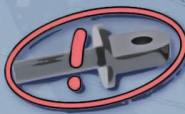

THIS PIN SHOULD BE
INSTALLED TO THE
BODY AT THE BEGINNING
OF THIS MANUAL, AT
THIS POINT WAIT
UNTIL THE LEG IS
COMPLETE BEFORE
CONNECTING TO THIS
PIN

Legend



SUPER GLUE



CLEAR



NO GLUE



FLAT HEAD



PHILLIPS HEAD



ALLEN KEY

Module 3: legs

THE FOLLOWING STEPS ARE UNIQUE FOR THE RIGHT LEG, FOLLOW THE SAME PREVIOUS STEPS FROM BEFORE AND NOTE THESE ADDITIONAL PARTS AND WHERE THEY GO

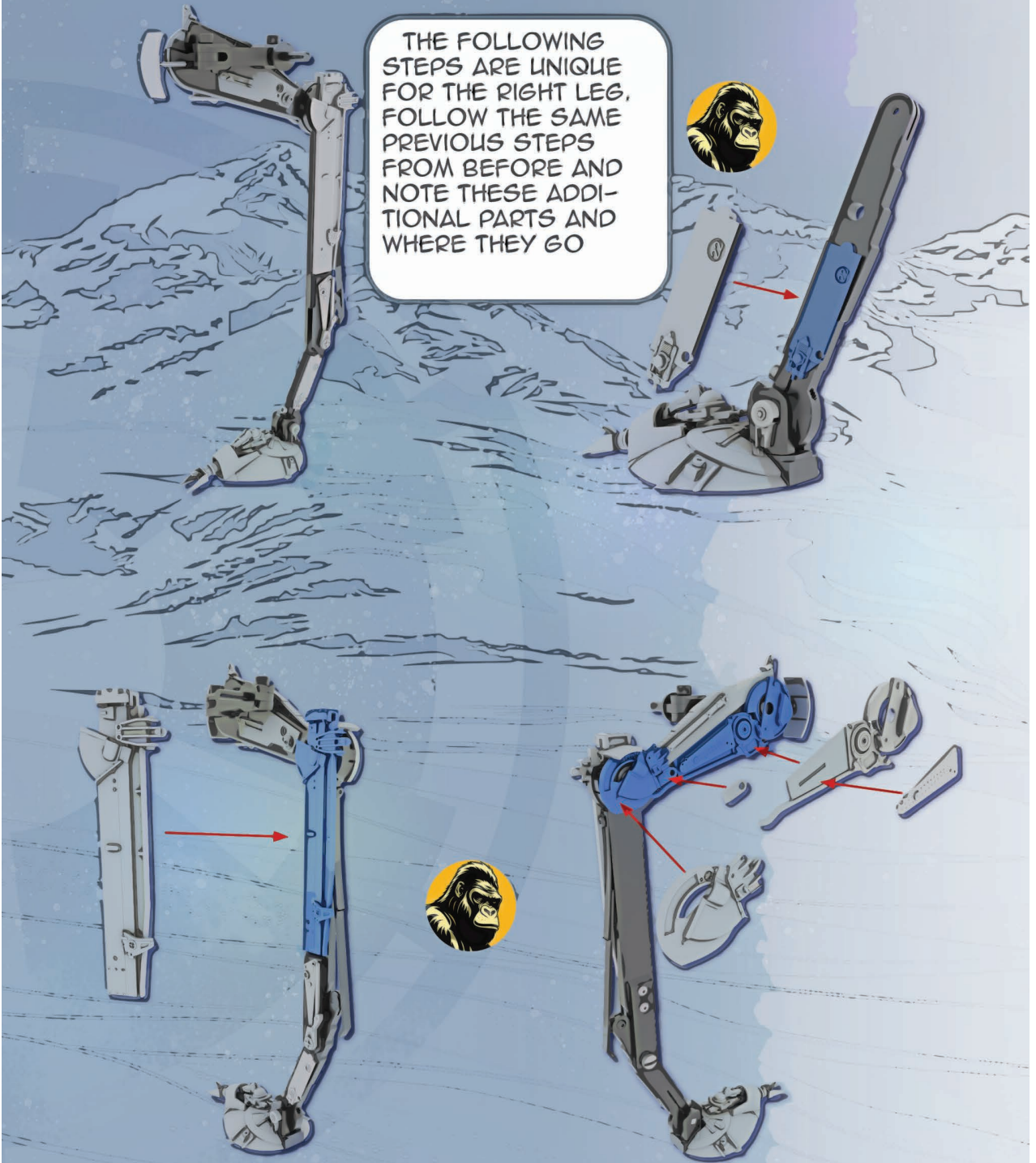

Legend



SUPER GLUE



CLEAR



NO GLUE



FLAT HEAD



PHILLIPS HEAD



ALLEN KEY

Module 4: hoses

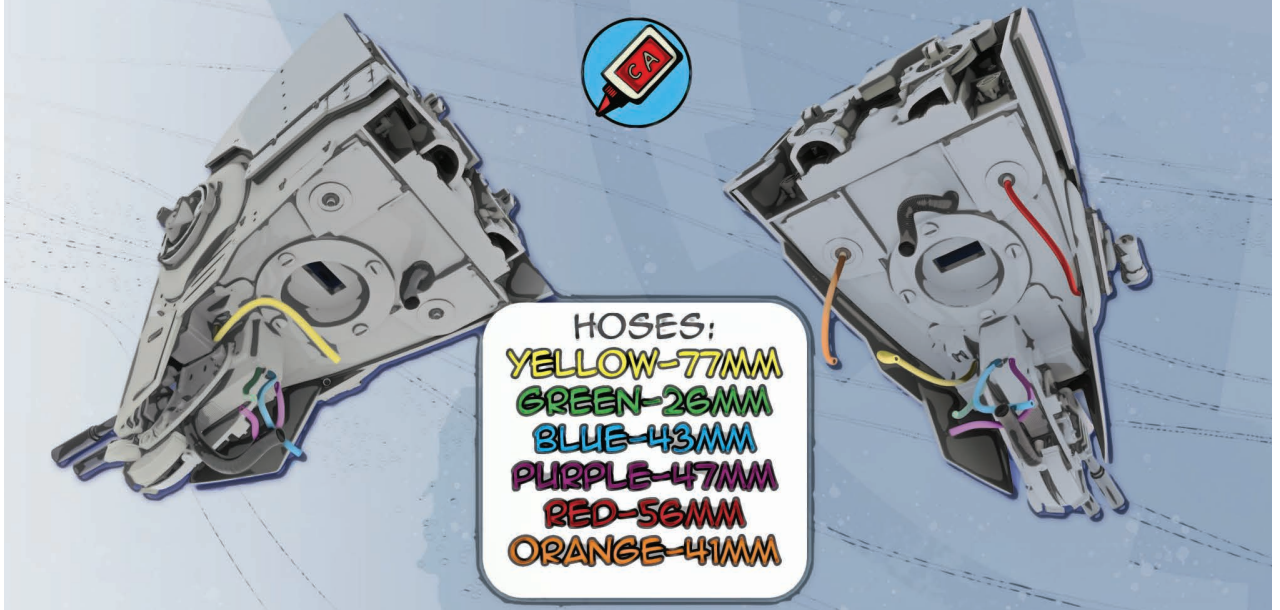
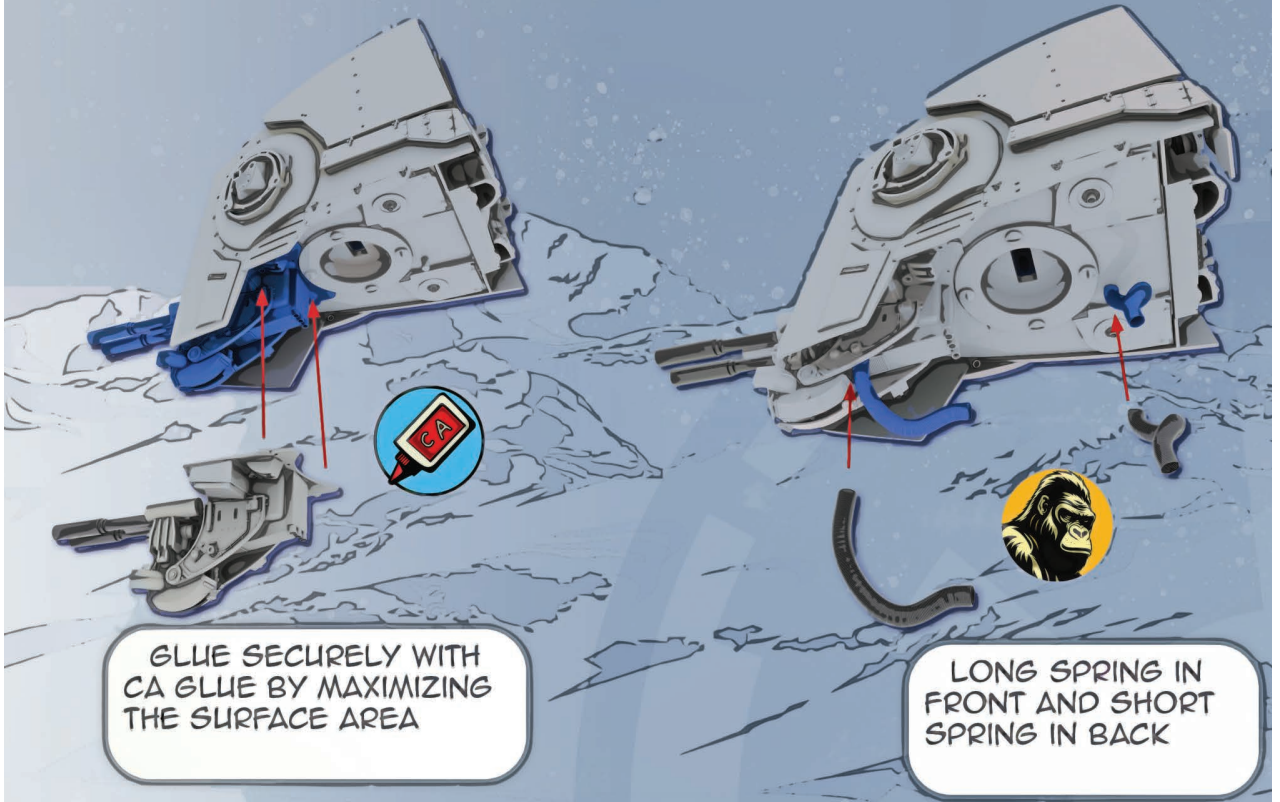

Legend



SUPER GLUE



CLEAR



NO GLUE



FLAT HEAD



PHILLIPS HEAD



ALLEN KEY

Module 5: assembly

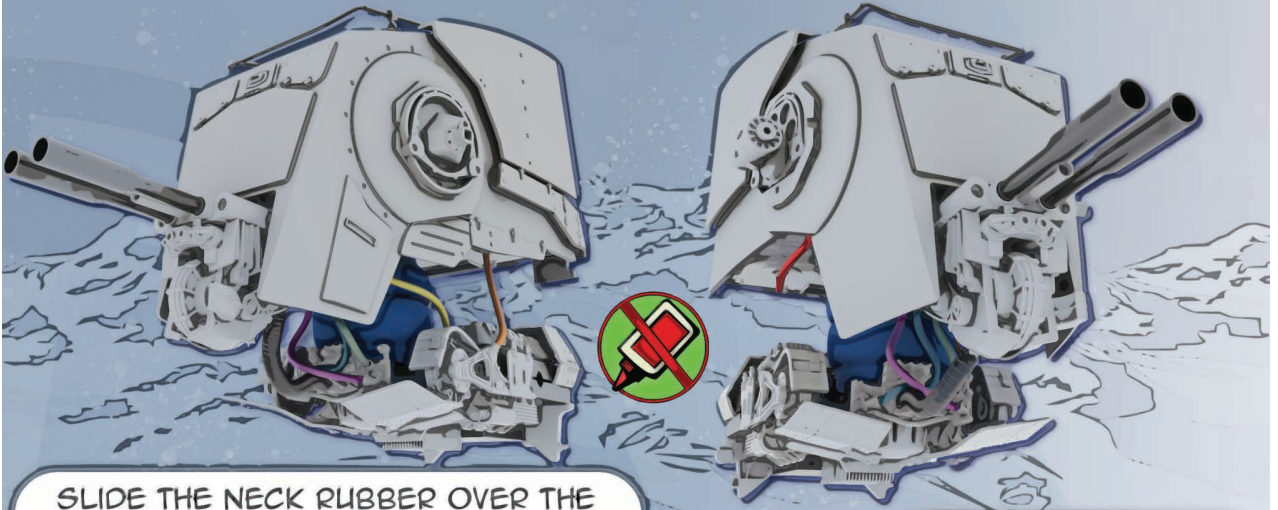

SLIDE THE NECK RUBBER OVER THE METAL NECK JOINT AND THEN SLIDE THE HEAD ON TOP OF THE JOINT

PRESS EACH SPRING OR SILICON INTO THEIR RESPECTIVE HOLES OR PINS AS LOCATED IN THESE IMAGES. DO NOT GLUE THEM TO BODY

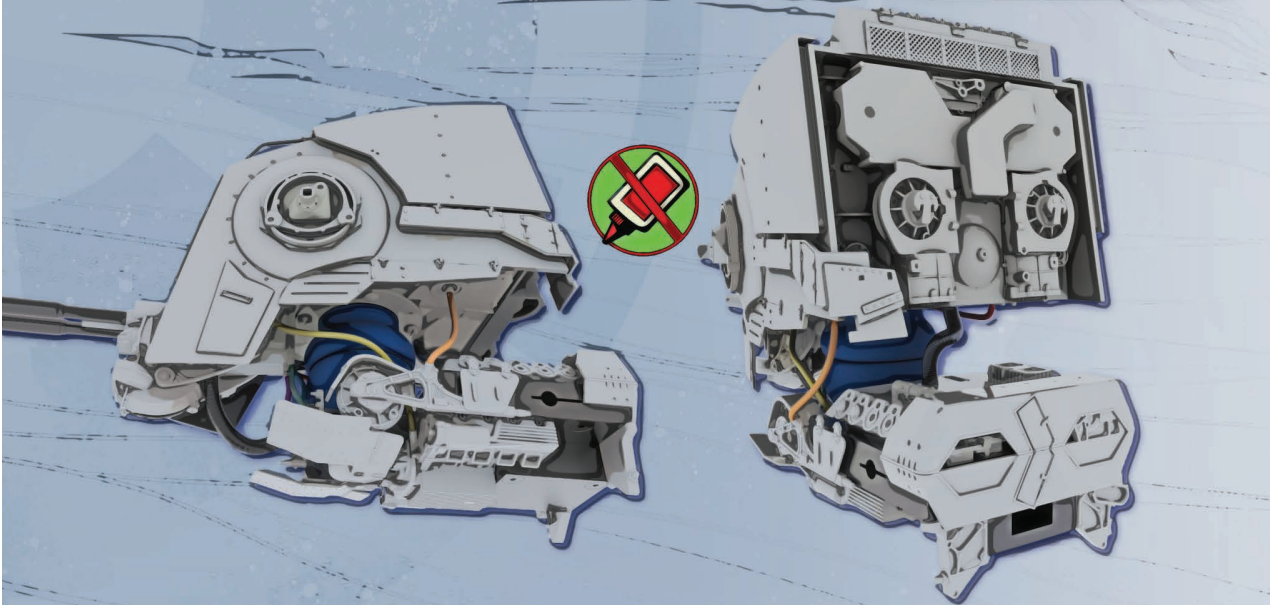

Legend



SUPER GLUE



CLEAR



NO GLUE



FLAT HEAD



PHILLIPS HEAD



ALLEN KEY

Module 5: assembly

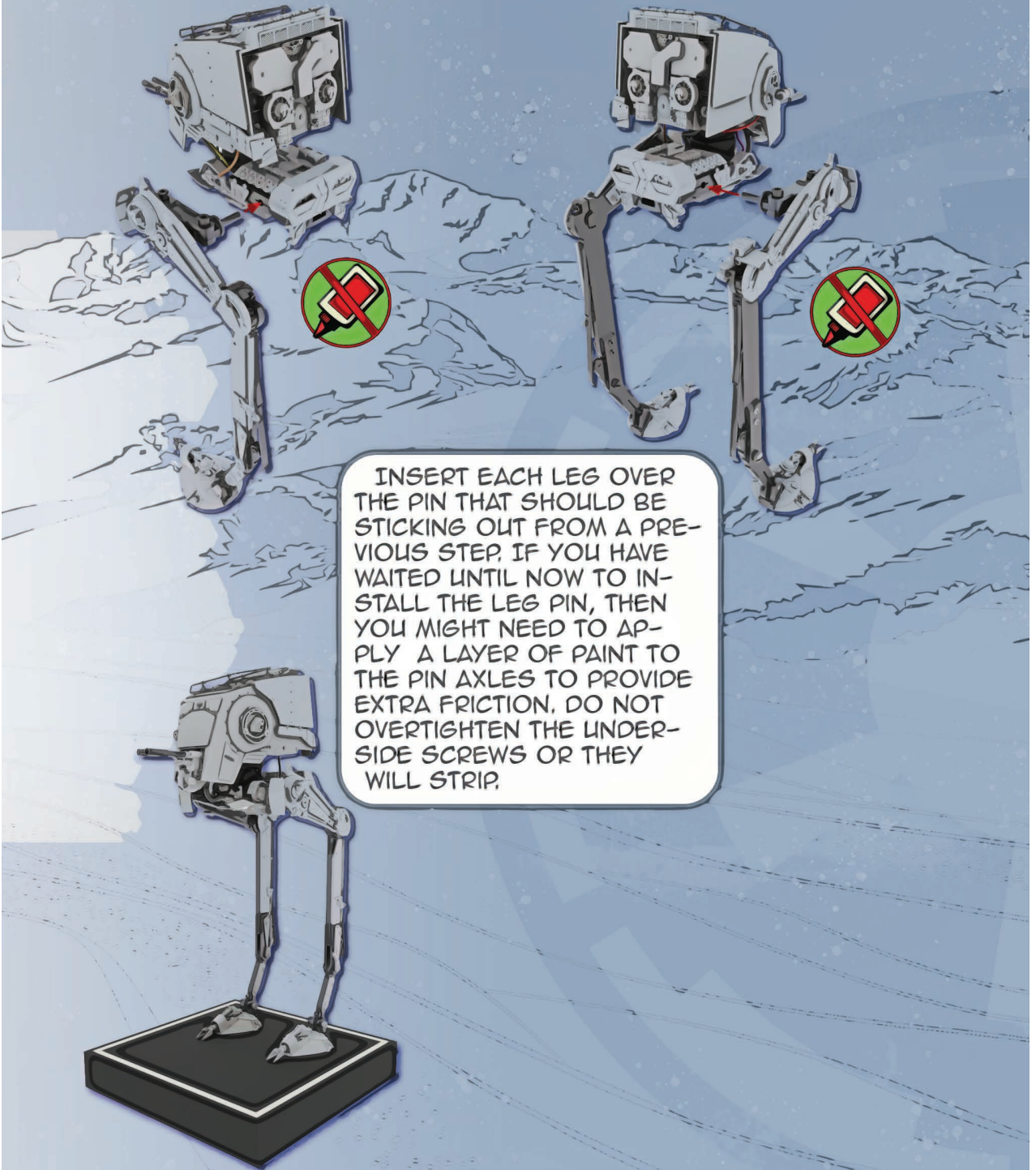

INSERT EACH LEG OVER THE PIN THAT SHOULD BE STICKING OUT FROM A PREVIOUS STEP. IF YOU HAVE WAITED UNTIL NOW TO INSTALL THE LEG PIN, THEN YOU MIGHT NEED TO APPLY A LAYER OF PAINT TO THE PIN AXLES TO PROVIDE EXTRA FRICTION. DO NOT OVERTIGHTEN THE UNDER-SIDE SCREWS OR THEY WILL STRIP.

Legend



SUPER GLUE



CLEAR



NO GLUE



FLAT HEAD



PHILLIPS HEAD



ALLEN KEY

Module 6: base

DRILL THOROUGH THE MARKED AREA ALL THE WAY. USE A 10MM BIT

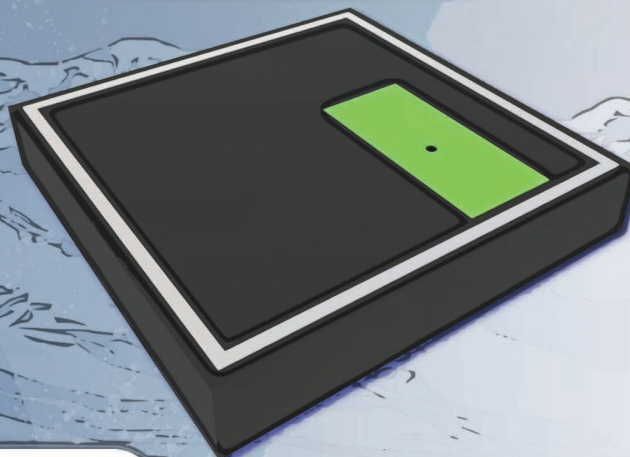
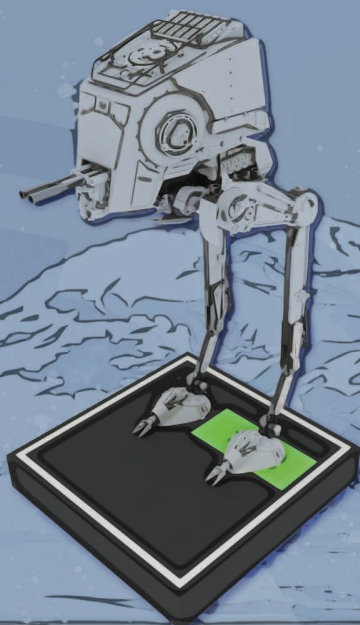

PLACE THE MODEL EXACTLY WHERE YOU WANT IT AND MEASURE WHERE THE FOOT HOLE IS LOCATED, PLACE A PIECE OF MASKING TAPE OVER THE SPACE AND MARK THE HOLE

USE PHILIPS HEAD TO INSTALL SCREW FROM THE BOTTOM

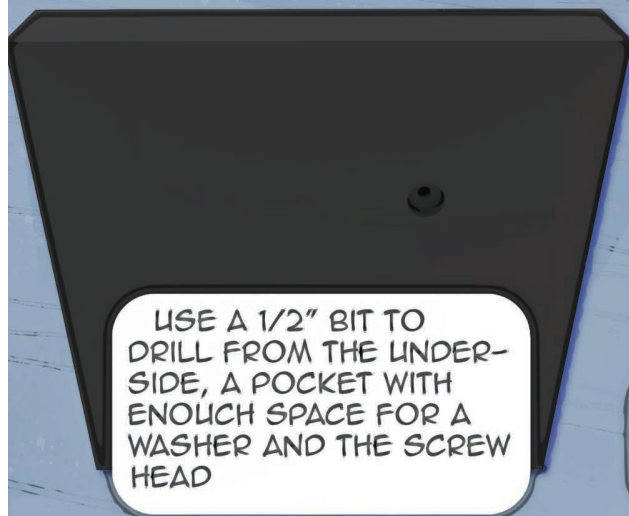

USE A 1/2" BIT TO DRILL FROM THE UNDER-SIDE, A POCKET WITH ENOUGH SPACE FOR A WASHER AND THE SCREW HEAD



PROVIDE YOUR OWN SCREW BASED ON YOUR DISPLAY NEED

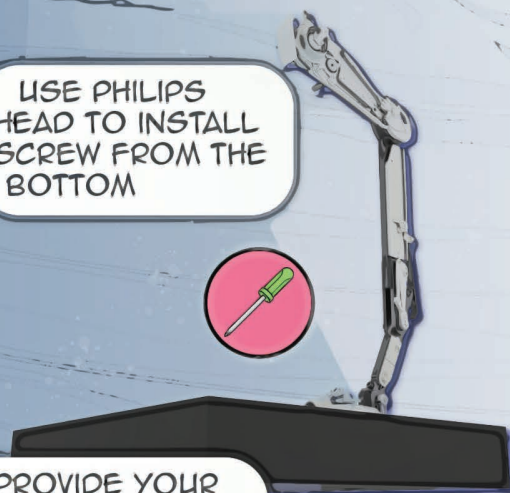

Legend



SUPER GLUE



CLEAR



NO GLUE



FLAT HEAD



PHILLIPS HEAD



ALLEN KEY

